

ACTIVITIES AND THERMODYNAMIC PROPERTIES OF SODIUM AMALGAMS AT 500–700°C

C. HIRAYAMA, K.F. ANDREW and R.L. KLEINOSKY

Westinghouse Research and Development Center, Pittsburgh, PA 15235 (U.S.A.)

(Received 25 September 1980)

ABSTRACT

The activities of Na and Hg in sodium amalgam have been determined from EMF and total pressure measurements at 500–700°C. These data have been used to calculate the partial vapor pressures and the thermodynamic properties of the elements in the amalgam.

INTRODUCTION

There have been several reports on the measurement of the sodium activities in sodium amalgams from EMF measurements between 200 and 450°C [1–4]. These measurements were made in concentration cells made with borosilicate glass, so that the upper temperature limit was severely limited because of the reaction of sodium with the glass. In these earlier reports there was satisfactory agreement on the EMF of the cells at 375°C. However, there was a wide variation in the temperature dependence of the EMF, with subsequent wide variation in the partial molar thermodynamic properties. Although the data of Bartlett et al. [3], as tabulated by Hultgren et al. [5], seem to be the most dependable, there is still some uncertainty in extrapolating these data to temperatures above 500°C. In these earlier reports, only the EMF measurements were made to determine the thermodynamic properties of sodium. Hauffe [1] was the only worker who calculated the activities of mercury by using the Gibbs–Duhem equation. There is presently a need for accurate activity data for both sodium and mercury in sodium amalgams at temperatures above 500°C.

In this work, we have determined the activities of sodium from EMF measurements of the cell $\text{Na}|\beta''\text{-Al}_2\text{O}_3|\text{Na}(\text{Hg})$ at temperatures of 498–611°C. The $\beta''\text{-Al}_2\text{O}_3$, which has a very high sodium ion conductivity, is compatible with liquid sodium in the measurement temperature range. The total pressures over the amalgams were also measured to determine the mercury partial pressures and activities.

EXPERIMENTAL

Materials

The sodium was nuclear grade obtained from Mine Safety Appliance (Pittsburgh, PA), while the mercury was a triple distilled material. The β'' - Al_2O_3 tube was obtained from Ceramatek, Inc. (Salt Lake City, UT). All sample preparations and loadings were made in an argon atmosphere in a glove box.

The amalgams for the total pressure measurements were prepared by weighing out appropriate quantities of the sodium and mercury into a Type 304 stainless steel crucible. The crucible was warmed on an electric hot plate and the amalgam was homogenized by stirring the liquid with a thin stainless steel tube. Chemical analysis of the amalgams for sodium showed that the nominal compositions were within ± 0.2 percentage points of those desired.

EMF Measurements

The concentration cell was constructed, as shown in Fig. 1, from Type 304 stainless steel. The inside dimensions of the reservoir were 2.86 cm diameter \times 1.90 cm high. The overall height of the cell was 28 cm from the base to the top of the stainless steel tube. The β'' - Al_2O_3 tube had a nominal inner diameter of 13 mm and outer diameter of 16 mm, with a length of 300 mm. The upper 5 cm of this tube was machined to a smooth, round configuration to assure hermetic sealing by means of the O-ring seal. The electrode to the sodium in the β'' - Al_2O_3 tube was a stainless steel rod of 3.2 mm diameter, while the stainless steel tube served as the electrode to the amalgam. Two thermocouples were welded onto the wall of the stainless steel reservoir, about 2 mm from the base, for sample temperature measurement and to control the furnace temperature. The furnace temperature was generally controlled to within $\pm 2^\circ\text{C}$.

The β'' - Al_2O_3 was loaded with 1.6 g of sodium, and the tube was hermetically sealed by coating the region of the feed-through through the Teflon plug with Apiezon W-600 wax, and the region around the ferrule nut was coated with vacuum epoxy. The hermetic sealing of the stainless steel tube was effected by pressurized O-ring seals, as shown in Fig. 1. The tightness of the seals was ascertained by a helium leak detector before loading the apparatus.

For the initial measurement, the cell reservoir was loaded with 8.3536 g of sodium, and the β'' - Al_2O_3 tube was lowered into the molten sodium after having warmed the reservoir on a hot plate to slightly above the melting point of sodium. After insertion of the β'' - Al_2O_3 tube, the cell was sealed by firmly tightening the gland nut. The cell was then removed from the glove box, and subsequently placed into a Marshall furnace to a depth of approximately 10 cm where the temperature was constant over the length of the reservoir section. Electrode leads were then attached for the EMF measurements. Steady state EMF values to within ± 0.1 mV were obtained shortly after constant temperature was attained. The cell EMF was measured with a

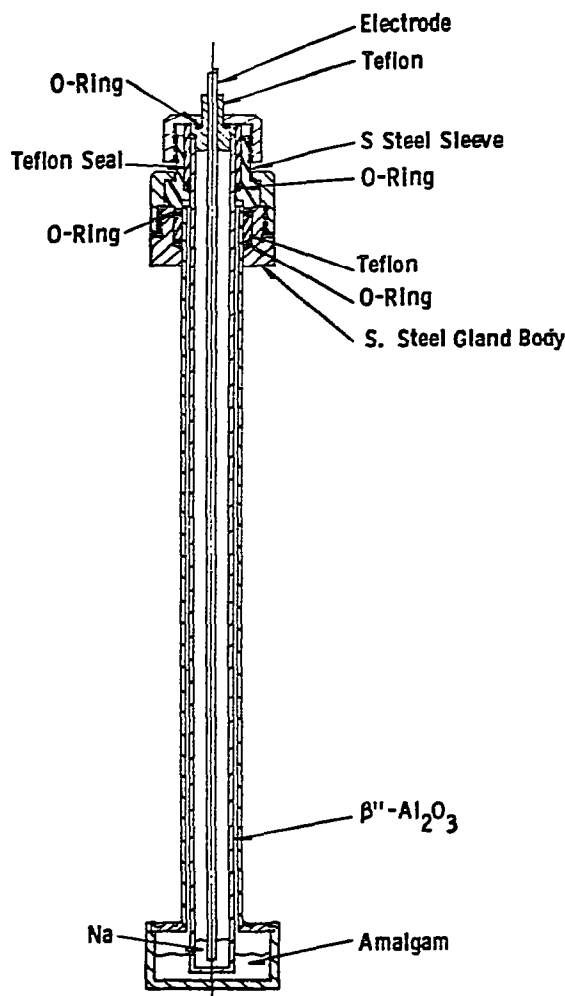

Fig. 1. Electrolytic cell.

Keithley Model 172A digital voltmeter, with an internal resistance of $>10^9 \Omega$. The EMF of the cell was $<0.15 \text{ mV}$ between 600 and 725°C .

After the measurement with the pure sodium was completed, the cell was allowed to cool to about 400°C while in the furnace, then subsequently removed to cool to room temperature. The cell was then placed on a hot plate in the glove box, and the $\beta''\text{-Al}_2\text{O}_3$ tube was carefully removed after the material in the reservoir had melted. The stainless steel tube was then cooled to room temperature, and the required quantity of mercury was carefully dropped into the reservoir. The tube was then placed onto the hot plate and the contents were mixed by swirling the tube. The $\beta''\text{-Al}_2\text{O}_3$ tube was inserted and the cell was further swirled while hot to homogenize the amalgam. For subsequent measurements, additional mercury was added to the amalgam to progressively dilute it with mercury.

The EMF measurements were recorded over at least 1 h after constant temperature was attained, and invariably the EMF was constant during this period. Also, the cell EMF was reproducible to within $\pm 0.2 \text{ mV}$ when mea-

measurements were made at increasing and at decreasing temperatures. This reproducibility shows that there was no concentration change during the measurements of a given amalgam.

Total pressure measurements

The total vapor pressure over the liquid amalgam was measured manometrically by a method which is similar to that used by Rodebush and Walters [6]. The measurement system used in our work is schematically shown in Fig. 2. The system was constructed with Type 304 stainless steel, except for the gas burette which was of Pyrex glass. All of the valves were stainless steel Nupro valves. The measurement system consisted of two essential sections: the section delineated as V_1 and that delineated as V_2 . A photograph of the V_2 section is shown in Fig. 3. The stainless steel tubings were of 1/4 in. outer diameter, and connections were of Swagelok fittings. The sample section was connected to the line (at A in Fig. 3) by a lightly greased standard taper stainless steel joint which was firmly held in place with a flange clamp as shown in Fig. 3. The complete system was leak-checked with a helium leak detector. The apparatus was calibrated by measuring the vapor pressures of pure mercury and sodium.

Initially, the volumes of sections V_1 and V_2 were measured by expanding a measured volume of argon from the gas burette, at room temperature and atmospheric pressure, into the evacuated system. From the pressure of the expanded gas, which was measured with the calibrated Baratron gauge, the total volume of the V_1 and V_2 sections was measured. Subsequently, the volume of section V_1 was determined in a similar manner. The volume in section V_1 was 12.71 cm^3 , and that in section V_2 was 116.27 cm^3 . The sample cell (C in Fig. 3) was 101.79 cm^3 . The sample temperature in the Marshall furnace was maintained to within $\pm 3^\circ \text{C}$.

Before each measurement section V_2 (shown in Fig. 3) was thoroughly cleaned and dried; the system was then evacuated overnight while the sample cell was heated. The evacuated system was transferred to the glove box, then

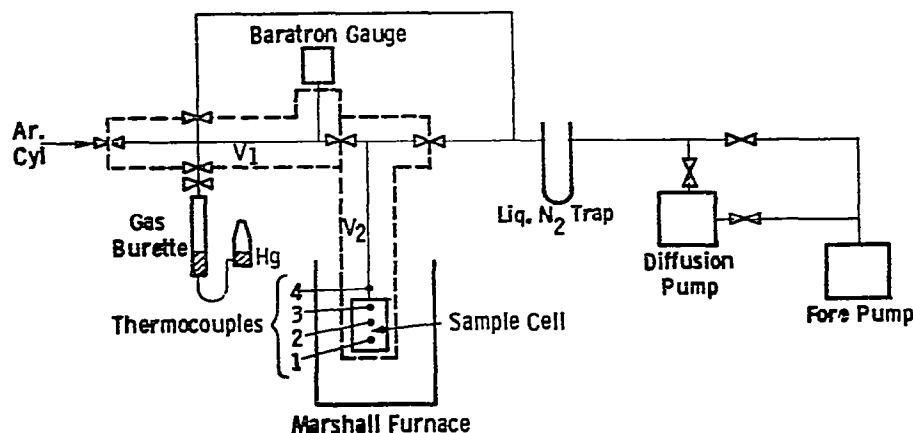

Fig. 2. Total vapor pressure system.

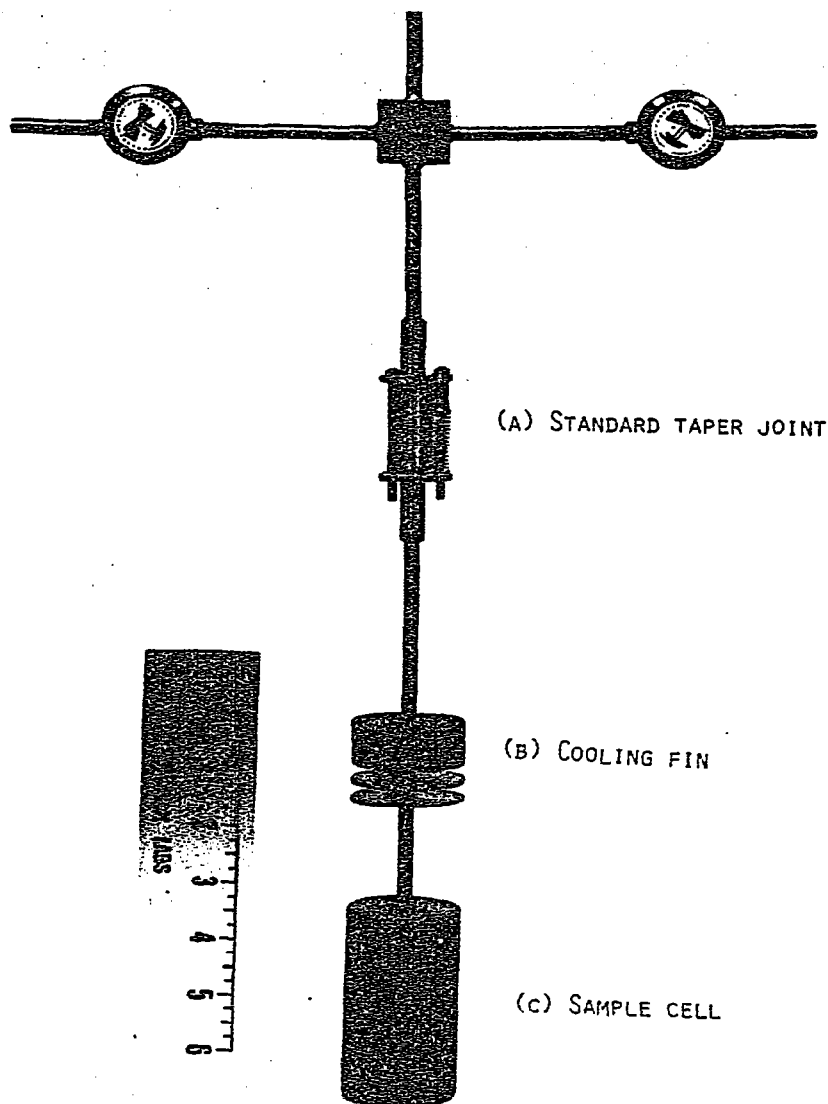

Fig. 3. Sample cell system (V_2) for total vapor pressure measurement.

opened to the argon atmosphere for sample loading. The tube was detached at the tapered joint, and the sample cell was loaded with 20–25 g of the molten amalgam by carefully injecting the amalgam with a stainless steel hypodermic needle. Care was taken not to allow the amalgam to touch the tube above the sample cell during sample injection. The loaded cell was then re-attached at the tapered joint and firmly clamped with the flange. After the valves were closed, the argon-filled system was then assembled onto the system of Fig. 2, and the system was evacuated. Subsequently, section V_1 was filled with argon, and this known quantity of argon was expanded into V_2 to determine the volume of the amalgam in the sample cell. This volume was usually about 5 cm³. Additional argon was introduced into the system so that the pressure was approximately 150 torr at room temperature.

After the system was loaded, the furnace was heated to the measurement

temperatures in approximately 3 h, and the temperature at each measurement point was equilibrated for 45 min. During this heating, the temperatures of the cell and the tubing just above the cell (see Fig. 2) were continuously monitored. Also, the cooling fins (as shown at B in Fig. 3) were continuously cooled with a fan to approximately room temperature. At temperature equilibrium, the temperature difference along the length of the sample cell, as measured by the three thermocouples, was within 5°C; the sample temperature was taken as the average of the three thermocouple readings. Also during the heating the pressure of the system was continuously monitored on the Baratron gauge.

The calculation of the amalgam vapor pressure was made by applying Dalton's law by adding the partial pressure contributions from the argon and the amalgam from the different parts of the apparatus. Details of the calculations are identical to those described by Rodebush and Walters [6].

The calibration measurements of pure mercury up to a pressure of 670 torr at 354°C agreed to within ±5% with the literature values [7]. The measured vapor pressure for pure sodium at temperatures up to 723°C also agreed to within ±5% with the vapor pressures reported by Rodebush and Walters [6].

RESULTS AND DISCUSSION

Activities and vapor pressures

For the concentration cell, $\text{Na}|\beta''\text{-Al}_2\text{O}_3|\text{Na}(\text{Hg})$, the EMF is given by the Nernst equation

$$E = \frac{-RT}{F} \ln a \quad (1)$$

where a is the sodium activity in the amalgam, F is the Faraday constant, and T is the absolute temperature. Since the transference number for the Na^+ ion is essentially unity through the $\beta''\text{-Al}_2\text{O}_3$, eqn. (1) measures the EMF exactly as a function of the sodium activity.

In the measurements of the cell EMF with the cell shown in Fig. 1, it was necessary to minimize the effect of amalgam distillation which might cause a concentration change in the amalgam. Therefore, the measurements were limited to temperatures below about 600°C. The reproducibility of the EMF at increasing and at decreasing temperatures shows that there was negligible concentration change during the measurements. Table 1 summarizes the EMF measurements for the six amalgams. All of the data in Table 1 were fitted to a linear equation of the type

$$E = A + B(t - 500)$$

where t is the temperature in °C. These equations are summarized in Table 2. The calculated EMF's were within ±1.5% of the experimental values for all of the amalgams. The equations in Table 2 were then used to extrapolate the cell EMF to 700°C.

TABLE 1
EMF of amalgam cells

At.% Na	Temp. (°C)	mV	At.% Na	Temp. (°C)	mV
90.0	575	9.18	69.9	499	38.86
	550	8.77		521	39.56
	515	8.37		540	40.08
	598	9.44		560	40.75
	596	9.46		589	41.56
80.0	500	20.20	60.6	599	41.83
	524	20.67		499	68.57
	552	21.19		518	69.41
	576	21.51		538	69.94
	601	22.11		559	70.68
	611	22.30		589	71.54
74.4	496	29.80	55.0	600	71.80
	520	30.31		498	95.77
	544	30.84		518	96.20
	569	31.62		538	96.61
	586	32.07		558	97.18
	599	32.50		590	98.00

The linearly increasing EMF with temperature is similar to that observed by Bartlett et al. [3] for amalgams with 0.5–0.7 at.% Na at temperatures of 400°C to approximately 460°C. Extrapolation of our data to these authors' temperature range for the 60.6 and 69.9 at.% Na amalgams shows satisfactory agreement. Bartlett et al. [3] used Pyrex glass for their solid electrolyte. The temperature coefficients, dE/dT , obtained by these authors, were 0.037 and 0.019 mV °C⁻¹ for 59.5 and 69.8 at.% Na amalgams, respectively. These compare with our values of 0.0315 and 0.0297 mV °C⁻¹ for the 60.6 and 69.9 at.% Na amalgam, respectively. Iverson and Recht [2] measured the EMF of some sodium amalgams at 350, 375, and 400°C. These authors also report a positive temperature coefficient of the EMF for their 55.6 at.%

TABLE 2
Least-squares fit of EMF to the equation
 $E = A + B(t - 500)$ (in mV)

At.% Na	A	$B \times 10^2$
90.0	8.149	1.340
80.0	20.199	1.864
74.4	29.811	2.635
69.9	38.914	2.973
60.6	68.734	3.148
55.0	95.767	2.439

Na amalgam, and extrapolation of our data to their temperature range shows fair agreement. However, Iverson and Recht [2] found a negative temperature coefficient of the EMF for their 80 at.% Na amalgam, whereas we found a positive coefficient. The EMF measurements of Bartlett et al. [3] agree with those of Iverson and Recht [2] over some of the composition ranges studied, but there are also disagreements over other composition ranges with regard to the sign of the EMF temperature coefficient. Our results are more in agreement with the more recent measurements of Bartlett et al. [3]. La Mantia and Bonilla [7] determined the EMF of the K—Hg system by using a KCl solid electrolyte cell up to 500°C. These authors report a positive temperature coefficient of the EMF for amalgam compositions from 45 to 90 at.% K. It appears that, although there is agreement of the EMF measurements for some compositions among the different authors, there is also disagreement, especially of the temperature dependence. Our measurements are the first made at temperatures above 500°C for this system.

The activity of sodium from 500 to 700°C was calculated using the data calculated from the equations in Table 2 and from eqn. (1). The sodium activities are summarized in Table 3, which also summarizes the mercury activities calculated from the total pressure data, as shown below.

Vapor pressures of the elements have been tabulated by Hultgren et al. [8] and in the JANAF Tables [9]. In the former tabulation, the sodium vapor is considered as a non-ideal monomer gas, whereas the JANAF Tables treat the vapor separately as the ideal monomer and dimer gas. Here, we have used the JANAF data to calculate the vapor pressures of Na(g) and Na₂(g), and the vapor pressure equations are summarized in Table 4. The mercury partial pressures were obtained by subtracting the sodium partial pressures from the total pressures.

The plots of the total pressures of the amalgams are shown in Fig. 4 and the equations for the total pressures are included in Table 4. The total vapor pressure for the 60.6 at.% Na amalgam was obtained by interpolation, as will be discussed below.

The mercury partial vapor pressures were obtained by subtracting the sodium partial pressures from the total pressures. Here, we used the smoothed pressure values which were calculated from the vapor pressure equations. The mercury partial pressures are shown in Table 4. It should be noted that the mercury partial pressure for the 60.6 at.% Na amalgam was obtained by interpolation. As shown in Fig. 5, the P_{Hg} shows an exponential dependence on the mole fraction, whereas the P_{Na} shows appreciable curvature on this plot. Although the data from only two temperatures are shown in Fig. 5, these relationships are typical for all temperatures. Therefore, a curve of the type

$$P_{\text{Hg}} = A \exp^{BX}$$

where A and B are constants and X is the at.% Na, was fitted to the P_{Hg} values at each temperature. The P_{Hg} for the 60.6 at.% Na amalgam was thus calculated at each temperature from these equations. These P_{Hg} values were then added to the P_{Na} and P_{Na_2} values at each temperature to obtain the

TABLE 3
Activities of Na and Hg

Amalgam composition X_{Na}		Temperature ($^{\circ}C$)										
		500	525	550	575	600	625	650	675	700		
0.90	Na	0.887	0.885	0.883	0.882	0.880	0.879	0.877	0.876	0.875		
	Hg $\times 10^3$	0.46	0.56	0.71	0.90	1.10	1.36	1.62	1.94	2.29		
0.80	Na	0.738	0.740	0.742	0.744	0.746	0.747	0.749	0.750	0.752		
	Hg $\times 10^3$	0.81	1.08	1.41	1.82	2.30	2.89	3.55	4.34	5.21		
0.744	Na	0.639	0.642	0.645	0.647	0.650	0.652	0.654	0.656	0.758		
	Hg $\times 10^3$	2.28	2.77	3.36	4.02	4.75	5.59	6.48	7.49	8.54		
0.699	Na	0.558	0.562	0.566	0.569	0.573	0.576	0.580	0.583	0.586		
	Hg $\times 10^3$	2.84	3.50	4.27	5.15	6.13	7.26	8.46	9.83	11.27		
0.606	Na	0.356	0.364	0.371	0.378	0.385	0.391	0.397	0.403	0.409		
	Hg $\times 10^3$	6.91	8.52	10.27	12.30	14.56	17.11	19.88	22.96	26.17		
0.55	Na	0.237	0.246	0.255	0.263	0.271	0.279	0.286	0.294	0.301		
	Hg $\times 10^3$	11.56	14.14	17.03	20.35	24.04	28.19	32.66	37.63	42.82		

TABLE 4

Vapor pressure equations, $\log P_i = A - B/T$ (torr), from 500 to 600°C

At.% Na	P_{total}		P_{Na}		P_{Na_2}		P_{Hg}	
	A	B	A	B	A	B	A	B
90	7.896	5488	7.253	5199	7.392	6217	7.814	5706
80	8.446	5836	7.212	5235	7.382	6333	8.568	6088
74.4	7.981	5233	7.195	5264	7.336	6398	7.878	5209
69.9	8.150	5304	7.179	5298	7.241	6409	8.089	5296
60.6	8.400	5228	7.224	5491	7.519	6967	8.372	5217
55	8.568	5192	7.205	5604	7.070	6821	8.553	5185

total pressures for this amalgam composition. The activities of mercury, summarized in Table 3, were calculated from these vapor pressures and the fugacities tabulated for this vapor by Hultgren et al. [5]. It is assumed in this work that vapor compounds of sodium with mercury do not make any significant contribution.

Thermodynamic properties

The partial molar free energy and entropy of solution for sodium in the amalgams were obtained using the equations

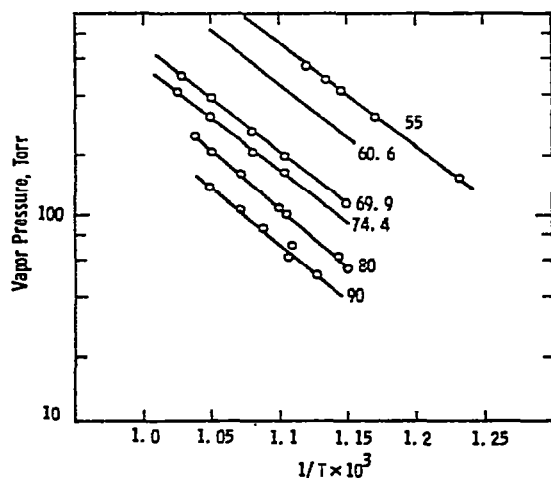

Fig. 4. Total pressures over amalgams. The numbers on the curves refer to the at.% Na in the amalgam.

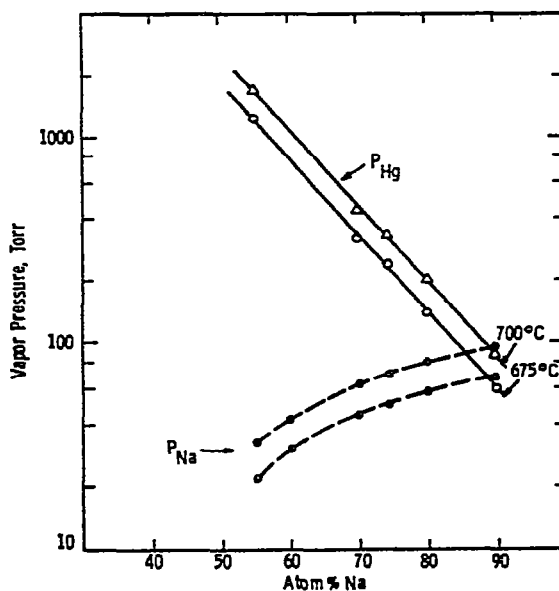

Fig. 5. Dependence of P_{Hg} and P_{Na} on the sodium concentration in amalgams at 675 and 700°C.

TABLE 5

Partial molar quantities for Na and ΔH for Hg at 550 and 650°C

X_{Na}	550°C						650°C					
	$-\Delta G$	$-\Delta G^{\text{xs}}$	ΔS	ΔS^{xs}	$-\Delta H$		$-\Delta G$	$-\Delta G^{\text{xs}}$	ΔS	ΔS^{xs}	$-\Delta H$	
	Na			Hg			Na			Hg		
0.55	9.36	7.11	2.35	-2.62	7.42	41.0	9.59	7.07	2.35	-2.62	7.42	41.0
0.606	6.78	4.71	3.04	-1.12	4.28	41.6	7.09	4.76	3.04	-1.12	4.28	41.6
0.699	3.90	2.19	2.87	-0.11	1.53	43.2	4.19	2.26	2.87	-0.11	1.53	43.2
0.744	3.00	1.50	2.54	0.08	0.91	41.4	3.26	1.57	2.54	0.08	0.91	41.4
0.800	2.04	0.82	1.80	-0.06	0.56	58.3	2.22	0.85	1.80	-0.06	0.56	58.3
0.900	0.85	0.20	1.29	0.41	0.21	51.0	0.98	0.28	1.29	0.41	0.21	51.0

 ΔG and ΔH in kJ mole⁻¹. ΔS in J K⁻¹ mole⁻¹.

$$\overline{\Delta G} = -FE \quad (2)$$

$$\overline{\Delta S} = F \frac{dE}{dT} \quad (3)$$

Table 5 summarizes the partial molar thermodynamic properties. The partial molar enthalpies in Table 5 were obtained from the relation

$$\overline{\Delta H} = T\overline{\Delta S} + \overline{\Delta G}$$

These enthalpies are in good agreement with the values calculated from the Gibbs-Helmholtz equation

$$\overline{\Delta H} = RT^2 \frac{d \ln a}{dT} \quad (4)$$

Table 5 also records the excess thermodynamic properties, $\overline{\Delta G}^{XS}$ and $\overline{\Delta S}^{XS}$. Figure 6 shows the variation of the partial molar entropy of solution of sodium as a function of the mole fraction concentration at the median temperature of 550°C. The data of Bartlett et al. [3], at 375°C, are also shown as a comparison. The data for the 55 and 60 at.% Na amalgam are in satisfactory agreement, but Bartlett et al.'s [3] entropy is significantly lower than our value at 70 at.% Na. Figure 7 shows the large, non-ideal behavior of Na and Hg in the amalgams. This non-ideal behavior is generally attributed to the existence of Hg-Na compounds in the liquid amalgam.

The data in Table 3 were fitted to equations of the type

$$\log a = A + B/T$$

where A and B are constants. These equations are summarized in Table 6, and were used to calculate the partial molar enthalpy of solutions of mercury (shown in Table 5) by utilizing eqn. (4). As the calculated data show,

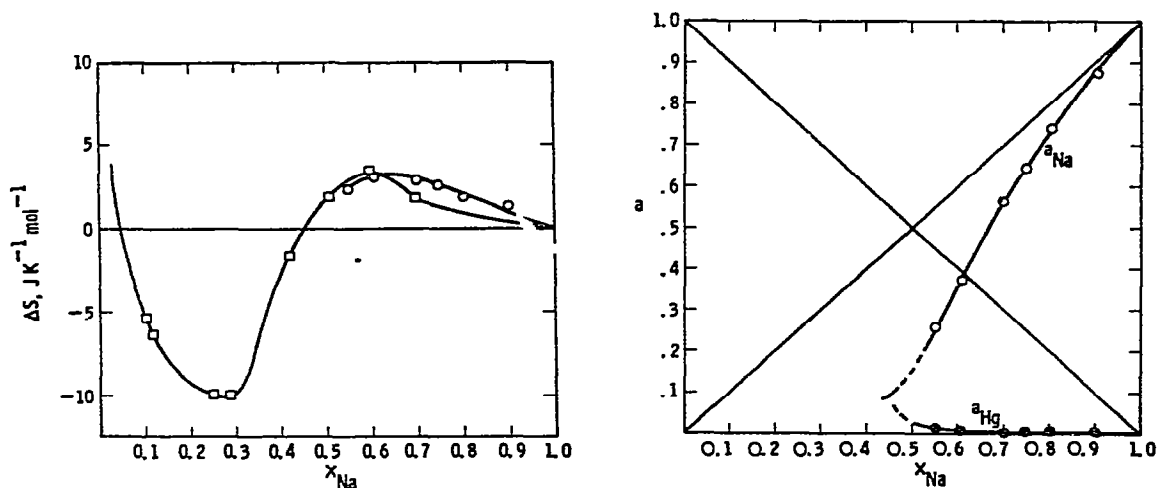

Fig. 6. Partial molar entropy as a function of the mole fraction of sodium. O, Present work at 550°C; □, Bartlett et al. [3] at 375°C.

Fig. 7. Activities of Na and Hg as a function of X_{Na} .

TABLE 6

Least-squares equations, $\log a_i = A + B/T$, for temperature dependence of activities

	A	B	Amalgam Composition X_{Na}
$\log a_{\text{Na}}$	-0.1219	-388.66	0.55
	-0.1578	-224.45	0.606
	-0.1507	-79.45	0.699
	-0.1328	-47.61	0.744
	-0.0930	-30.09	0.800
	-0.0718	14.60	0.900
$\log a_{\text{Hg}}$	0.8342	-2142	0.55
	0.6540	-2174	0.606
	0.3710	-2255	0.699
	0.1571	-2165	0.744
	0.8476	-3044	0.800
	0.0976	-2665	0.900

the dissolution of mercury into sodium results in the evolution of a considerable quantity of heat.

The activity coefficients of Na and Hg were calculated at 500, 550, 600, and 650°C from the data in Table 3. The activity coefficients were then fitted at each of these temperatures to a fourth order-equation of the type

$$\log \gamma = A + BX + CX^2 + DX^3 + EX^4$$

Table 7 summarizes these equations. The activity coefficients calculated from these equations agree to within $\pm 1.5\%$ with those obtained by

$$\gamma_i = a_i/X_i$$

with the a_i from Table 3.

In previous studies on the thermodynamics of sodium amalgams using the glass cells, Hauffe [1] was the only author who reported on the activities of

TABLE 7

Polynomial equations, $\log \gamma_i = A + BX_i + CX_i^2 + DX_i^3 + EX_i^4$, where X_i = mole fraction of Na or Hg

	Temp. (°C)	A	B	C	D	E
$\log \gamma_{\text{Na}}$	500	-8.800	36.721	-58.742	42.561	-11.740
	550	-7.181	29.043	-44.932	31.450	-8.380
	600	-6.253	24.855	-37.698	25.803	-6.707
	650	-5.372	20.847	-30.744	20.375	-5.175
$\log \gamma_{\text{Hg}}$	500	-0.0237	-43.982	265.47	-624.7	521.9
	550	-0.6013	-29.656	180.23	-421.2	351.4
	600	-0.9950	-18.517	112.23	-256.8	213.0
	650	-1.3261	-9.010	54.31	-117.0	95.3

Hg in addition to those of sodium. All of the other authors reported only the sodium thermodynamic properties. Hauffe only measured the EMF of the amalgam cell to calculate the sodium activities; the mercury activities were obtained by utilizing the Gibbs—Duhem equation. In our work we have determined the mercury activities experimentally by combining the sodium vapor pressures with the measured total pressures over the amalgams. La Mantia and Bonilla [7] made similar studies to ours in the K—Hg system at high temperatures. Extrapolation of our mercury activities to 375°C shows that Hauffe's activities are at least 50% higher than our values at the same sodium concentration in the Na—Hg system. Our mercury data were assessed for thermodynamic consistency by utilizing the Gibbs—Duhem equation

$$\ln \frac{\gamma''_{\text{Hg}}}{\gamma'_{\text{Hg}}} = - \int_{X'_{\text{Na}}}^{X''_{\text{Na}}} \frac{X_{\text{Na}}}{X_{\text{Hg}}} d \ln \gamma_{\text{Na}} \quad (5)$$

Equation (5) should be obeyed by any two component system at equilibrium. The quantity on the right-hand side of eqn. (5) was obtained by utilizing the polynomial equations for $\log \gamma_{\text{Na}}$ in Table 7 to evaluate the integral. The agreement of the calculated $\gamma''_{\text{Hg}}/\gamma'_{\text{Hg}}$ agreed to within $\pm 5\%$ with the activity coefficient ratios obtained from the data in Table 3. The probable error in our activity data for Hg is estimated to be approximately $\pm 5\%$, this being the estimated error in the total vapor pressure measurements. The mercury activities, therefore, show thermodynamic consistency with the Gibbs—Duhem equations.

CONCLUSIONS

(1) Earlier literature data for the activities of Na in amalgams of concentration higher than 60 at.% Na cannot be accurately extrapolated to temperatures in the range 600—700°C.

(2) The present data allow the calculation of dependable vapor pressures over sodium amalgams at temperatures up to at least 700°C.

REFERENCES

- 1 K. Hauffe, *Z. Elektrochem.*, 46 (1940) 348.
- 2 M.L. Iverson and H.L. Recht, *J. Chem. Eng. Data*, 12 (1967) 262.
- 3 H.E. Bartlett, A.J. Neethling and P. Crowther, *J. Chem. Thermodyn.*, 2 (1970) 583.
- 4 M.A. Bykova and A.G. Morachevskii, *Zh. Prikl. Khim.*, 46 (1973) 326 of English translation.
- 5 R. Hultgren, P.D. Desai, D.T. Hawkins, M. Gleiser and K.K. Kelley, *Selected Values of the Thermodynamic Properties of Binary Alloys*, Am. Soc. Metals, Metals Park, OH, 1973, pp. 962—969.
- 6 W.H. Rodebush and E.G. Walters, *J. Am. Chem. Soc.*, 52 (1930) 2654.

- 7 C.R. La Mantia and C.F. Bonilla, in J.R. Moszynski (Ed.), Proc. 4th Symposium on Thermophysical Properties, Am. Soc. Mech. Eng., New York, NY, 1968, pp. 58—71.
- 8 R. Hultgren, P.D. Desai, D.T. Hawkins, M. Gleiser, K.K. Kelley and D.D. Wagman, Selected Values of the Thermodynamic Properties of the Elements, Am. Soc. Metals, Metals Park, OH, 1973.
- 9 D.R. Stull and H. Prophet, JANAF Thermochemical Tables, NSRDS-NBS37, U.S. Government Printing Office, 1971, 2nd edn.